

QUALLCO

PROFESSIONAL LIGHT COMPONENTS

2022



Incassi Gypsolyte • Gypsolyte fixtures



Type	Part n°	Dimensions mm	Standard	Colour	mm	Packing box dimensions (mm)	Packing box (kg)
ARAGON Q1B	B9129G050Q1B	120x120x55h	MR16	White	125x125	170x170x110	0,64

Vedere pagina 168 per i kit che includono la lampadina LED - See page 168 for kits including LED lamp

Incasso in Gypsolyte per controsoffitti (per moduli LED)

- Incasso invisibile per controsoffitti
- Dopo aver rasato a gesso il controsoffitto, l'incasso risulta parte integrante del soffitto stesso e può essere tinteggiato
- Apertura per installazione 125x125 mm.
- Adatto a moduli LED standard MR16

Gypsolyte fitting for counter ceiling (for LED modules)

- Invisible fitting for counter ceilings
- Once the counter ceiling is finished with smoothing plaster, the fitting is almost invisible and can be painted together with the ceiling
- Installation hole mm 125x125
- Suitable for standard MR16 LED modules

Einbaustrahler aus Gypsolyte für Unterdecken (für Led-Modulen geeignet)

- Unsichtbare Einbaustrahler für Unterdecken
- Sobald die Unterdecke durch Gips glatt gemacht ist, wird der Einbaustrahler fast unsichtbar und kann zusammen mit der Unterdecke gemalt werden
- Montageöffnung 125x125 mm.
- Für Standard MR16 LED-Module geeignet

Encastrable en Gypsolyte pour plafond (pour modules à LED)

- Encastrable invisible pour faux plafond
- Après avoir lissé le faux-plafond, le boîtier encastrable devient partie intégrante du faux-plafond lui même et peut être peint
- Ouverture dans le plafond pour l'installation: 125x125 mm.
- Adapté aux modules LED MR16 standard

Cazoleta para falso techo (para módulos de LED) in Gypsolyte

- Cazoleta para falso techo Gypsolyte (para módulos de LED)
- Cazoleta invisible para falsos techos
- Una vez terminado el falso techo con yeso la carcasa es casi invisible y puede ser pintado junto con el techo
- Medidas del orificio para la instalación: 125x125 mm.
- Apropiado para módulos estándar de LED MR16



55

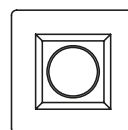

73 120

- 73 -

120





ARAGON XL

QUALIKO^{srl}
PROFESSIONAL LIGHT COMPONENTS

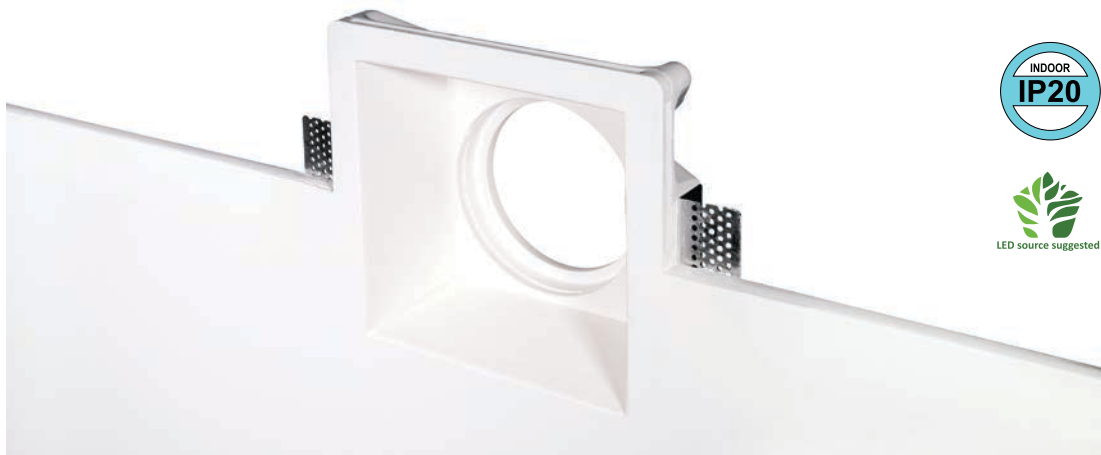

Incassi Gypsolyte • Gypsolyte fixtures



Type	Part n°	Dimensions mm	Standard	Colour	 mm	Packing box dimensions (mm)	Packing box (kg)
ARAGON XL Q1B	B9247G111Q1B	200x200x75h	AR111	White	203x203	250x270x130	1,80

Vedere pagina 168 per i kit che includono la lampadina LED e il driver - See page 168 for kits including LED lamp and driver

Incasso in Gypsolyte per controsoffitti (per moduli LED)

- Incasso invisibile per controsoffitti
- Dopo aver rasato a gesso il controsoffitto, l'incasso risulta parte integrante del soffitto stesso e può essere tinteggiato
- Apertura per installazione 203x203 mm.
- Adatto a moduli LED standard AR111

Gypsolyte fitting for counter ceiling (for LED modules)

- Invisible fitting for counter ceilings
- Once the counter ceiling is finished with smoothing plaster, the fitting is almost invisible and can be painted together with the ceiling
- Installation hole mm 203x203
- Suitable for standard AR111 LED modules

Einbaustrahler aus Gypsolyte für Unterdecken (für Led-Modulen geeignet)

- Unsichtbare Einbaustrahler für Unterdecken
- Sobald die Unterdecke durch Gips glatt gemacht ist, wird der Einbaustrahler fast unsichtbar und kann zusammen mit der Unterdecke gemalt werden
- Montageöffnung 203x203mm.
- Für Standard AR111 LED-Module geeignet

Encastrable en Gypsolyte pour plafond (pour modules à LED)

- Encastrable invisible pour faux plafond
- Après avoir lissé le faux-plafond, le boîtier encastrable devient partie intégrante du faux-plafond lui même et peut être peint
- Ouverture dans le plafond pour l'installation: 203x203 mm.
- Adapté aux modules led AR111 standard

Cazoleta para falso techo (para módulos de LED) in Gypsolyte

- Cazoleta para falso techo Gypsolyte (para módulos de led)
- Cazoleta invisible para falsos techos
- Una vez terminado el falso techo con yeso la carcasa es casi invisible y puede ser pintado junto con el techo
- Medidas del orificio para la instalación 203x203 mm

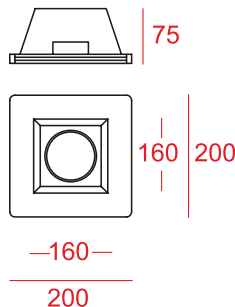

Optional driver 12V AC 30W
A10MT0300008

Optional 12V AC-DC LED bulb AR111:
A440QL11130M2 (13W - 3000K)
A440QL11140M2 (13W - 4000K)



ARAGON GLASS

QUALIKO^{srl}
PROFESSIONAL LIGHT COMPONENTS



Incassi Gypsolyte • Gypsolyte fixtures



Type	Part n°	Dimensions mm	Standard	Colour	 mm	Packing box dimensions (mm)	Packing box (kg)
ARAGON GLASS	B9128GV50Q1B	120x120x55h	MR16	White	125x125	170x170x110	0,64

Vedere pagina 168 per i kit che includono la lampadina LED - See page 168 for kits including LED lamp

Incasso in Gypsolyte per controsoffitti (per moduli LED)

- L'aggiunta di un vetro satinato permette di eliminare l'abbagliamento della fonte di luce
- Incasso invisibile per controsoffitti
- Dopo aver rasato a gesso il controsoffitto, l'incasso risulta parte integrante del soffitto stesso e può essere tinteggiato
- Apertura per installazione 125x125 mm.
- Adatto a moduli LED standard MR16

Gypsolyte fitting for counter ceiling (for LED modules)

- A frosted glass avoids dazzle
- Invisible fitting for counter ceilings
- Once the counter ceiling is finished with smoothing plaster, the fitting is almost invisible and can be painted together with the ceiling
- Installation hole mm 125x125
- Suitable for standard MR16 LED modules

Einbaustrahler aus Gypsolyte für Unterdecken (für Led-Modulen geeignet)

- Der Zusatz einer Milchglas macht es möglich, den Schein der Lichtquelle zu beseitigen
- Unsichtbare Einbaustrahler für Unterdecken
- Sobald die Unterdecke durch Gips glatt gemacht ist, wird der Einbaustrahler fast unsichtbar und kann zusammen mit der Unterdecke gemalt werden
- Montageöffnung 125x125 mm.
- Für Standard MR16 LED-Module geeignet

Encastrable en Gypsolyte pour plafond (pour modules à LED)

- L'ajout d'une vitre satinée permet d'éliminer l'éblouissement dû à la source de lumière
- Encastrable invisible pour faux plafond
- Après avoir lissé le faux-plafond, le boîtier encastrable devient partie intégrante du faux-plafond lui même et peut être peint
- Ouverture dans le plafond pour l'installation: 125x125 mm.
- Adapté aux modules LED MR16 standard

Cazoleta para falso techo (para módulos de LED) in Gypsolyte

- Un cristal esmerilado evita los deslumbramientos
- Cazoleta para falso techo Gypsolyte (para módulos de LED)
- Cazoleta invisible para falsos techos
- Una vez terminado el falso techo con yeso la carcasa es casi invisible y puede ser pintado junto con el techo
- Medidas del orificio para la instalación 125x125 mm.
- Apropriadado para módulos estándar de LED MR16

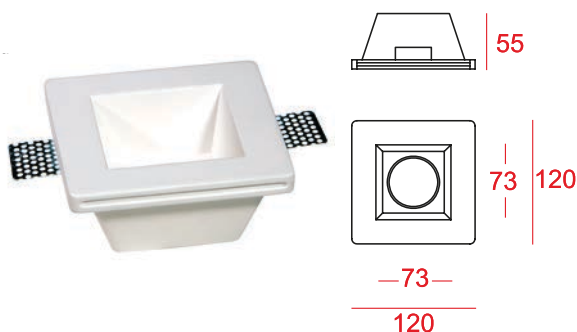



ARAGON FLAT

QUALIKO^{srl}
PROFESSIONAL LIGHT COMPONENTS

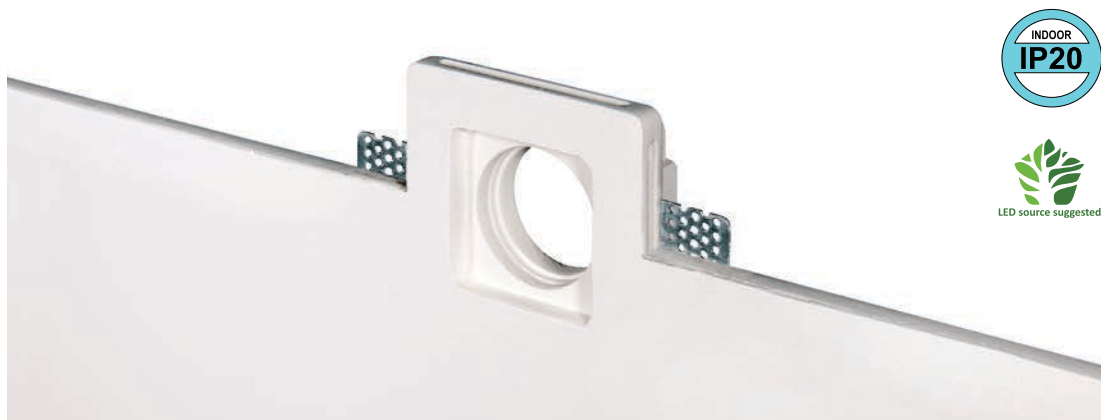

Incassi Gypsolyte • Gypsolyte fixtures



Type	Part n°	Dimensions mm	Standard	Colour	 mm	Packing box dimensions (mm)	Packing box (kg)
ARAGON FLAT Q1B	B9222G050Q1B	100x100x27h	MR16	White	105x105	150x150x80	0,40

Vedere pagina 168 per i kit che includono la lampadina LED - See page 168 for kits including LED lamp

Incasso in Gypsolyte per controsoffitti (per moduli LED)

- Incasso invisibile per controsoffitti
- Dopo aver rasato a gesso il controsoffitto, l'incasso risulta parte integrante del soffitto stesso e può essere tinteggiato
- Apertura per installazione 105x105 mm.
- Adatto a moduli LED standard MR16

Gypsolyte fitting for counter ceiling (for LED modules)

- Invisible fitting for counter ceilings
- Once the counter ceiling is finished with smoothing plaster, the fitting is almost invisible and can be painted together with the ceiling
- Installation hole mm 105x105
- Suitable for standard MR16 LED modules

Einbaustrahler aus Gypsolyte für Unterdecken (für Led-Modulen geeignet)

- Unsichtbare Einbaustrahler für Unterdecken
- Sobald die Unterdecke durch Gips glatt gemacht ist, wird der Einbaustrahler fast unsichtbar und kann zusammen mit der Unterdecke gemalt werden
- Montageöffnung 105x105 mm.
- Für Standard MR16 LED-Module geeignet

Encastrable en Gypsolyte pour plafond (pour modules à LED)

- Encastrable invisible pour faux plafond
- Après avoir lissé le faux-plafond, le boîtier encastrable devient partie intégrante du faux-plafond lui même et peut être peint
- Ouverture dans le plafond pour l'installation: 105x105 mm.
- Adapté aux modules LED MR16 standard

Cazoleta para falso techo (para módulos de LED) in Gypsolyte

- Cazoleta para falso techo Gypsolyte (para módulos de LED)
- Cazoleta invisible para falsos techos
- Una vez terminado el falso techo con yeso la carcasa es casi invisible y puede ser pintado junto con el techo
- Medidas del orificio para la instalación 105x105 mm.
- Apropriado para módulos estándar de LED MR16

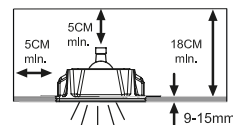
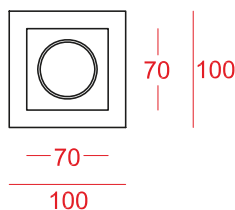

ARAGON TWIN

QUALIKO^{srl}
PROFESSIONAL LIGHT COMPONENTS



Incassi Gypsolyte • Gypsolyte fixtures



Type	Part n°	Dimensions mm	Standard	Colour	 mm	Packing box dimensions (mm)	Packing box (kg)
ARAGON TWIN Q2B	B9223G050Q2B	215x120x55h	2x MR16	White	200x125	260x165x110	1,10

Vedere pagina 168 per i kit che includono la lampadina LED - See page 168 for kits including LED lamp

Incasso in Gypsolyte per controsoffitti (per moduli LED)

- Incasso invisibile per controsoffitti
- Dopo aver rasato a gesso il controsoffitto, l'incasso risulta parte integrante del soffitto stesso e può essere tinteggiato
- Apertura per installazione 220x125 mm.
- Adatto a moduli LED standard MR16

Gypsolyte fitting for counter ceiling (for LED modules)

- Invisible fitting for counter ceilings
- Once the counter ceiling is finished with smoothing plaster, the fitting is almost invisible and can be painted together with the ceiling
- Installation hole mm 220x125
- Suitable for standard MR16 LED modules

Einbaustrahler aus Gypsolyte für Unterdecken (für Led-Modulen geeignet)

- Unsichtbare Einbaustrahler für Unterdecken
- Sobald die Unterdecke durch Gips glatt gemacht ist, wird der Einbaustrahler fast unsichtbar und kann zusammen mit der Unterdecke gemalt werden
- Montageöffnung 220x125 mm.
- Für Standard MR16 LED-Module geeignet

Encastrable en Gypsolyte pour plafond (pour modules à LED)

- Encastrable invisible pour faux plafond
- Après avoir lissé le faux-plafond, le boîtier encastrable devient partie intégrante du faux-plafond lui même et peut être peint
- Ouverture dans le plafond pour l'installation: 220x125 mm.
- Adapté aux modules LED MR16 standard

Cazoleta para falso techo (para módulos de LED) in Gypsolyte

- Cazoleta para falso techo Gypsolyte (para módulos de LED)
- Cazoleta invisible para falsos techos
- Una vez terminado el falso techo con yeso la carcasa es casi invisible y puede ser pintado junto con el techo
- Medidas del orificio para la instalación 220x125 mm.
- Apropriado para módulos estándar de LED MR16

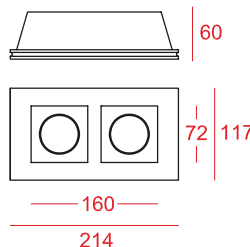



Incassi Gypsolyte • Gypsolyte fixtures

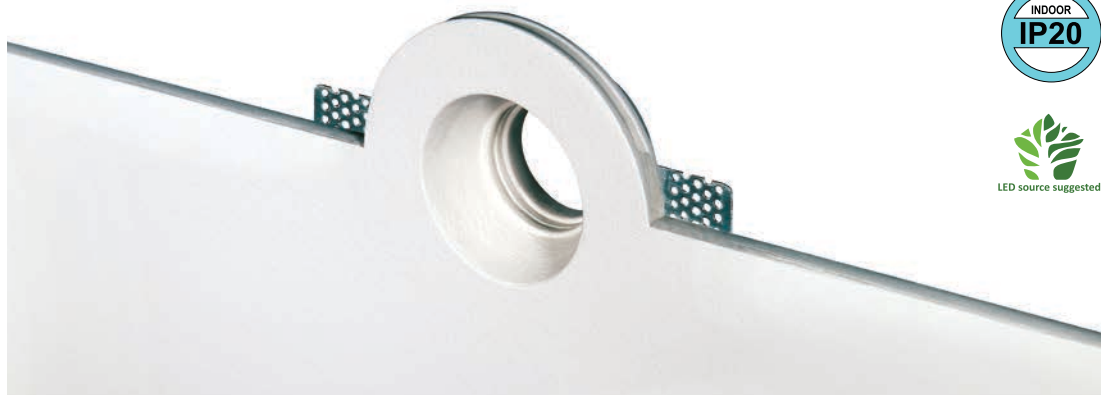

Type	Part n°	Dimensions mm	Standard	Colour	 mm	Packing box dimensions (mm)	Packing box (kg)
OBLÒ T1B	B9130G050T1B	Ø130x45h	MR16	White	Ø135	170x170x110	0,57

Vedere pagina 168 per i kit che includono la lampadina LED - See page 168 for kits including LED lamp

Incasso in Gypsolyte per controsoffitti (per moduli LED)

- Incasso invisibile per controsoffitti
- Dopo aver rasato a gesso il controsoffitto, l'incasso risulta parte integrante del soffitto stesso e può essere tinteggiato
- Apertura per installazione Ø135 mm.
- Adatto a moduli LED standard MR16

Gypsolyte fitting for counter ceiling (for LED modules)

- Invisible fitting for counter ceilings
- Once the counter ceiling is finished with smoothing plaster, the fitting is almost invisible and can be painted together with the ceiling
- Installation hole mm Ø135
- Suitable for standard MR16 LED modules

Einbaustrahler aus Gypsolyte für Unterdecken (für Led-Modulen geeignet)

- Unsichtbare Einbaustrahler für Unterdecken
- Sobald die Unterdecke durch Gips glatt gemacht ist, wird der Einbaustrahler fast unsichtbar und kann zusammen mit der Unterdecke gemalt werden
- Montageöffnung Ø135 mm.
- Für Standard MR16 LED-Module geeignet

Encastrable en Gypsolyte pour plafond (pour modules à LED)

- Encastrable invisible pour faux plafond
- Après avoir lissé le faux-plafond, le boîtier encastrable devient partie intégrante du faux-plafond lui même et peut être peint
- Ouverture dans le plafond pour l'installation: Ø135 mm.
- Adapté aux modules LED MR16 standard

Cazoleta para falso techo (para módulos de LED) in Gypsolyte

- Cazoleta para falso techo Gypsolyte (para módulos de LED)
- Cazoleta invisible para falsos techos
- Una vez terminado el falso techo con yeso la carcasa es casi invisible y puede ser pintado junto con el techo
- Medidas del orificio para la instalación Ø135 mm.
- Apropriado para módulos estándar de LED MR16

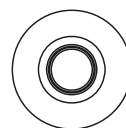



- Ø73 -
Ø130



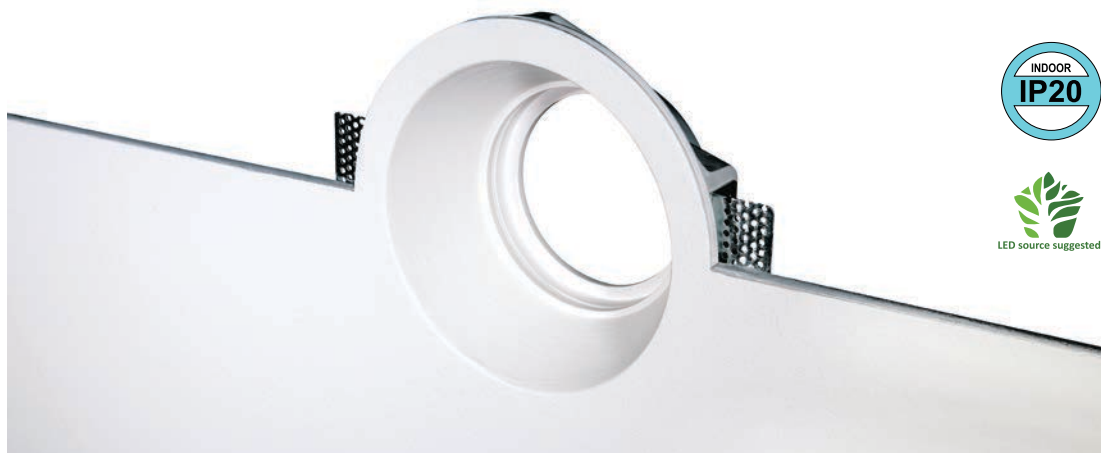

Incassi Gypsolyte • Gypsolyte fixtures



Type	Part n°	Dimensions mm	Standard	Colour	 mm	Packing box dimensions (mm)	Packing box (kg)
OBLÒ XL T1B	B9248G111T1B	Ø200x75h	AR111	White	Ø205	250x270x130	1,40

Vedere pagina 168 per i kit che includono la lampadina LED e il driver - See page 168 for kits including LED lamp and driver

Incasso in Gypsolyte per controsoffitti (per moduli LED)

- Incasso invisibile per controsoffitti
- Dopo aver rasato a gesso il controsoffitto, l'incasso risulta parte integrante del soffitto stesso e può essere tinteggiato
- Apertura per installazione Ø 205 mm.
- Adatto a moduli LED standard AR111

Gypsolyte fitting for counter ceiling (for LED modules)

- Invisible fitting for counter ceilings
- Once the counter ceiling is finished with smoothing plaster, the fitting is almost invisible and can be painted together with the ceiling
- Installation hole mm Ø 205 mm.
- Suitable for standard AR111 LED modules

Einbaustrahler aus Gypsolyte für Unterdecken (für Led-Modulen geeignet)

- Unsichtbare Einbaustrahler für Unterdecken
- Sobald die Unterdecke durch Gips glatt gemacht ist, wird der Einbaustrahler fast unsichtbar und kann zusammen mit der Unterdecke gemalt werden
- Montageöffnung Ø 205 mm.
- Für Standard AR111 LED-Module geeignet

Encastrable en Gypsolyte pour plafond (pour modules à LED)

- Encastrable invisible pour faux plafond
- Après avoir lissé le faux-plafond, le boîtier encastrable devient partie intégrante du faux-plafond lui même et peut être peint
- Ouverture dans le plafond pour l'installation: Ø205 mm.
- Adapté aux modules led AR111 standard.

Cazoleta para falso techo (para módulos de LED) in Gypsolyte

- Cazoleta para falso techo Gypsolyte (para módulos de led)
- Cazoleta invisible para falsos techos
- Una vez terminado el falso techo con yeso la carcasa es casi invisible y puede ser pintado junto con el techo
- Medidas del orificio para la instalación Ø 205 mm.
- Apropriadado para módulos estándar de led AR111.

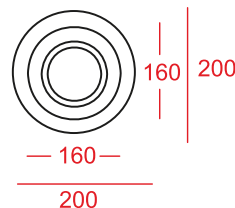

Optional driver 12V AC 30W
A10MT0300008

Optional 12V AC-DC LED bulb AR111:
A440QL11130M2 (13W - 3000K)
A440QL11140M2 (13W - 4000K)





Incassi Gypsolyte • Gypsolyte fixtures



Type	Part n°	Dimensions mm	Standard	Colour	 mm	Packing box dimensions (mm)	Packing box (kg)
OBLÒ GLASS T1B	B9132GV50T1B	Ø120x63h	MR16	White	Ø125	200x170x113	0,64

Vedere pagina 168 per i kit che includono la lampadina LED - See page 168 for kits including LED lamp

Incasso in Gypsolyte per controsoffitti (per moduli LED)

- L'aggiunta di un vetro satinato permette di eliminare l'abbagliamento della fonte di luce
- Incasso invisibile per controsoffitti
- Dopo aver rasato a gesso il controsoffitto, l'incasso risulta parte integrante del soffitto stesso e può essere tinteggiato
- Apertura per installazione Ø125 mm.
- Adatto a moduli LED standard MR16

Gypsolyte fitting for counter ceiling (for LED modules)

- A frosted glass avoids dazzle
- Invisible fitting for counter ceilings
- Once the counter ceiling is finished with smoothing plaster, the fitting is almost invisible and can be painted together with the ceiling
- Installation hole mm Ø125
- Suitable for standard MR16 LED modules

Einbaustrahler aus Gypsolyte für Unterdecken (für Led-Modulen geeignet)

- Der Zusatz einer Milchglas macht es möglich, den Schein der Lichtquelle zu beseitigen
- Unsichtbare Einbaustrahler für Unterdecken
- Sobald die Unterdecke durch Gips glatt gemacht ist, wird der Einbaustrahler fast unsichtbar und kann zusammen mit der Unterdecke gemalt werden
- Montageöffnung Ø125 mm.
- Für Standard MR16 LED-Module geeignet

Encastrable en Gypsolyte pour plafond (pour modules à LED)

- L'ajout d'une vitre satinée permet d'éliminer l'éblouissement dû à la source de lumière
- Encastrable invisible pour faux plafond
- Après avoir lissé le faux-plafond, le boîtier encastrable devient partie intégrante du faux-plafond lui même et peut être peint
- Ouverture dans le plafond pour l'installation: Ø125 mm.
- Adapté aux modules LED MR16 standard

Cazoleta para falso techo (para módulos de LED) in Gypsolyte

- Un cristal esmerilado evita los deslumbramientos
- Cazoleta para falso techo Gypsolyte (para módulos de LED)
- Cazoleta invisible para falsos techos
- Una vez terminado el falso techo con yeso la carcasa es casi invisible y puede ser pintado junto con el techo
- Medidas del orificio para la instalación Ø125 mm.
- Apropiado para módulos estándar de LED MR16

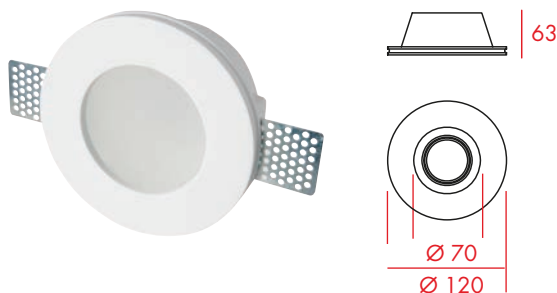



OBLÒ FLAT

QUALIKO^{srl}
PROFESSIONAL LIGHT COMPONENTS

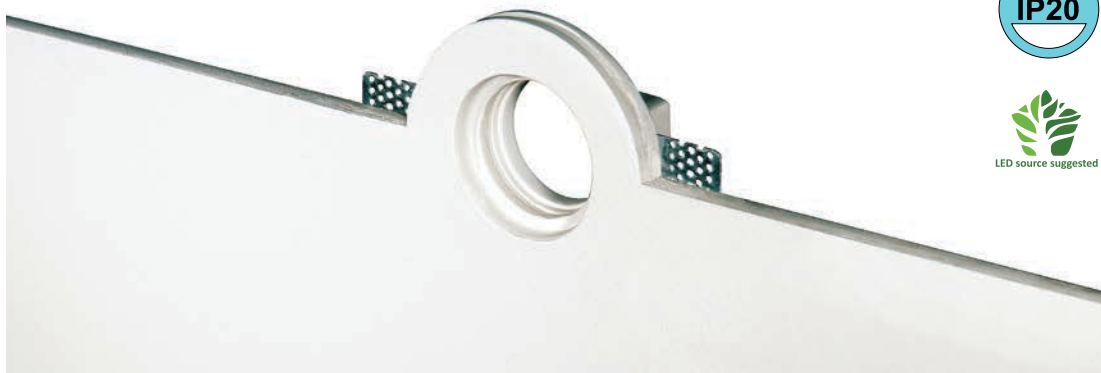

Incassi Gypsolyte • Gypsolyte fixtures



Type	Part n°	Dimensions mm	Standard	Colour	 mm	Packing box dimensions (mm)	Packing box (kg)
OBLÒ FLAT T1B	B9224G050T1B	Ø100x27h	MR16	White	Ø105	150x150x80	0,26

Vedere pagina 168 per i kit che includono la lampadina LED - See page 168 for kits including LED lamp

Incasso in Gypsolyte per controsoffitti (per moduli LED)

- Incasso invisibile per controsoffitti
- Dopo aver rasato a gesso il controsoffitto, l'incasso risulta parte integrante del soffitto stesso e può essere tinteggiato
- Apertura per installazione Ø105 mm.
- Adatto a moduli LED standard MR16

Gypsolyte fitting for counter ceiling (for LED modules)

- Invisible fitting for counter ceilings
- Once the counter ceiling is finished with smoothing plaster, the fitting is almost invisible and can be painted together with the ceiling
- Installation hole mm Ø105
- Suitable for standard MR16 LED modules

Einbaustrahler aus Gypsolyte für Unterdecken (für Led-Modulen geeignet)

- Unsichtbare Einbaustrahler für Unterdecken
- Sobald die Unterdecke durch Gips glatt gemacht ist, wird der Einbaustrahler fast unsichtbar und kann zusammen mit der Unterdecke gemalt werden
- Montageöffnung Ø105 mm.
- Für Standard MR16 LED-Module geeignet

Encastrable en Gypsolyte pour plafond (pour modules à LED)

- Encastrable invisible pour faux plafond
- Après avoir lissé le faux-plafond, le boîtier encastrable devient partie intégrante du faux-plafond lui même et peut être peint
- Ouverture dans le plafond pour l'installation: Ø105 mm.
- Adapté aux modules LED MR16 standard

Cazoleta para falso techo (para módulos de LED) in Gypsolyte

- Cazoleta para falso techo Gypsolyte (para módulos de LED)
- Cazoleta invisible para falsos techos
- Una vez terminado el falso techo con yeso la carcasa es casi invisible y puede ser pintado junto con el techo
- Medidas del orificio para la instalación Ø105 mm.
- Apropiado para módulos estándar de LED MR16



- Ø60-
Ø100

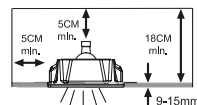



Incassi Gypsolyte • Gypsolyte fixtures



Type	Part n°	Dimensions mm	Standard	Colour	 mm	Packing box dimensions (mm)	Packing box (kg)
SLIDE Q1B	B9131G050Q1B	120x120x40h	MR16	White	125x125	170x170x110	0,52

Vedere pagina 168 per i kit che includono la lampadina LED - See page 168 for kits including LED lamp

Incasso in Gypsolyte per controsoffitti (per moduli LED)

- Incasso invisibile per controsoffitti
- Dopo aver rasato a gesso il controsoffitto, l'incasso risulta parte integrante del soffitto stesso e può essere tinteggiato
- Apertura per installazione 125x125 mm.
- Adatto a moduli LED standard MR16

Gypsolyte fitting for counter ceiling (for LED modules)

- Invisible fitting for counter ceilings
- Once the counter ceiling is finished with smoothing plaster, the fitting is almost invisible and can be painted together with the ceiling
- Installation hole mm 125x125
- Suitable for standard MR16 LED modules

Einbaustrahler aus Gypsolyte für Unterdecken (für Led-Modulen geeignet)

- Unsichtbare Einbaustrahler für Unterdecken
- Sobald die Unterdecke durch Gips glatt gemacht ist, wird der Einbaustrahler fast unsichtbar und kann zusammen mit der Unterdecke gemalt werden
- Montageöffnung 125x125 mm.
- Für Standard MR16 LED-Module geeignet

Encastrable en Gypsolyte pour plafond (pour modules à LED)

- Encastrable invisible pour faux plafond
- Après avoir lissé le faux-plafond, le boîtier encastrable devient partie intégrante du faux-plafond lui même et peut être peint
- Ouverture dans le plafond pour l'installation: 125x125 mm.
- Adapté aux modules LED MR16 standard

Cazoleta para falso techo (para módulos de LED) in Gypsolyte

- Cazoleta para falso techo Gypsolyte (para módulos de LED)
- Cazoleta invisible para falsos techos
- Una vez terminado el falso techo con yeso la carcasa es casi invisible y puede ser pintado junto con el techo
- Medidas del orificio para la instalación 125x125 mm.
- Apropriado para módulos estándar de LED MR16

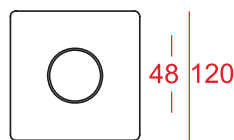

DIAGONAL

QUALIKO^{srl}
PROFESSIONAL LIGHT COMPONENTS



Incassi Gypsolyte • Gypsolyte fixtures

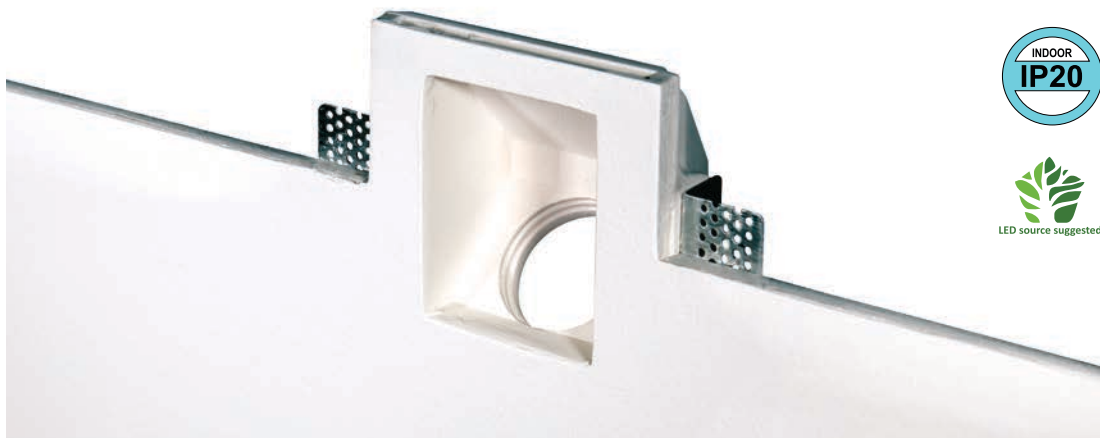

Type	Part n°	Dimensions mm	Standard	Colour	 mm	Packing box dimensions (mm)	Packing box (kg)
DIAGONAL Q1B	B9229G050Q1B	120x120x65h	MR16	White	125x125	170x170x110	0,75

Vedere pagina 168 per i kit che includono la lampadina LED - See page 168 for kits including LED lamp

Incasso in Gypsolyte per controsoffitti (per moduli LED)

- Incasso invisibile per controsoffitti
- Dopo aver rasato a gesso il controsoffitto, l'incasso risulta parte integrante del soffitto stesso e può essere tinteggiato
- Apertura per installazione 125x125 mm.
- Adatto a moduli LED standard MR16

Gypsolyte fitting for counter ceiling (for LED modules)

- Invisible fitting for counter ceilings
- Once the counter ceiling is finished with smoothing plaster, the fitting is almost invisible and can be painted together with the ceiling
- Installation hole mm 125x125
- Suitable for standard MR16 LED modules

Einbaustrahler aus Gypsolyte für Unterdecken (für Led-Modulen geeignet)

- Unsichtbare Einbaustrahler für Unterdecken
- Sobald die Unterdecke durch Gips glatt gemacht ist, wird der Einbaustrahler fast unsichtbar und kann zusammen mit der Unterdecke gemalt werden
- Montageöffnung 125x125 mm.
- Für Standard MR16 LED-Module geeignet

Encastrable en Gypsolyte pour plafond (pour modules à LED)

- Encastrable invisible pour faux plafond
- Après avoir lissé le faux-plafond, le boîtier encastrable devient partie intégrante du faux-plafond lui même et peut être peint
- Ouverture dans le plafond pour l'installation: 125x125 mm.
- Adapté aux modules LED MR16 standard

Cazoleta para falso techo (para módulos de LED) in Gypsolyte

- Cazoleta para falso techo Gypsolyte (para módulos de LED)
- Cazoleta invisible para falsos techos
- Una vez terminado el falso techo con yeso la carcasa es casi invisible y puede ser pintado junto con el techo
- Medidas del orificio para la instalación 125x125 mm.



65

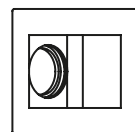

70 120

88

120





Incassi Gypsolyte • Gypsolyte fixtures

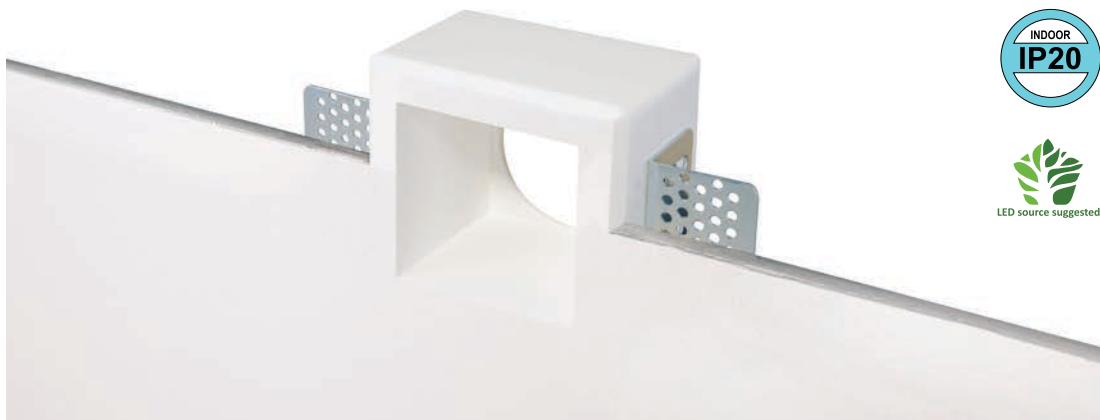

Type	Part n°	Dimensions mm	Standard	Colour	 mm	Packing box dimensions (mm)	Packing box (kg)
BEAT Q1B	B9284G050Q1B	80x80x53h	MR16	White	83x83	125x125x100	0,45

Vedere pagina 168 per i kit che includono la lampadina LED - See page 168 for kits including LED lamp

Incasso in Gypsolyte per controsoffitti (per moduli LED)

- Incasso invisibile per controsoffitti
- Dopo aver rasato a gesso il controsoffitto, l'incasso risulta parte integrante del soffitto stesso e può essere tinteggiato
- Apertura per installazione 83x83 mm.
- Adatto a moduli LED standard MR16

Gypsolyte fitting for counter ceiling (for LED modules)

- Invisible fitting for counter ceilings
- Once the counter ceiling is finished with smoothing plaster, the fitting is almost invisible and can be painted together with the ceiling
- Installation hole mm 83x83
- Suitable for standard MR16 LED modules

Einbaustrahler aus Gypsolyte für Unterdecken (für Led-Modulen geeignet)

- Unsichtbare Einbaustrahler für Unterdecken
- Sobald die Unterdecke durch Gips glatt gemacht ist, wird der Einbaustrahler fast unsichtbar und kann zusammen mit der Unterdecke gemalt werden
- Montageöffnung 83x83 mm.
- Für Standard MR16 LED-Module geeignet

Encastrable en Gypsolyte pour plafond (pour modules à LED)

- Encastrable invisible pour faux plafond
- Après avoir lissé le faux-plafond, le boîtier encastrable devient partie intégrante du faux-plafond lui même et peut être peint
- Ouverture dans le plafond pour l'installation: 83x83 mm.
- Adapté aux modules LED MR16 standard

Cazoleta para falso techo (para módulos de LED) in Gypsolyte

- Cazoleta para falso techo Gypsolyte (para módulos de LED)
- Cazoleta invisible para falsos techos
- Una vez terminado el falso techo con yeso la carcasa es casi invisible y puede ser pintado junto con el techo
- Medidas del orificio para la instalación 83x83 mm.
- Apropriado para módulos estándar de LED MR16

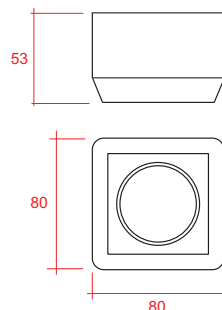



Incassi Gypsolyte • Gypsolyte fixtures

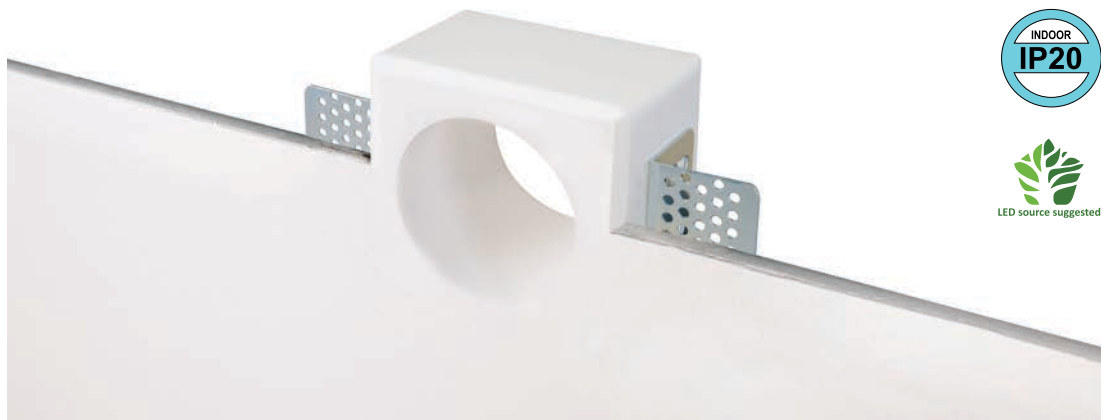

Type	Part n°	Dimensions mm	Standard	Colour	 mm	Packing box dimensions (mm)	Packing box (kg)
SOUL T1B	B9285G050T1B	80x80x53h	MR16	White	83x83	125x125x100	0,45

Vedere pagina 168 per i kit che includono la lampadina LED - See page 168 for kits including LED lamp

Incasso in Gypsolyte per controsoffitti (per moduli LED)

- Incasso invisibile per controsoffitti
- Dopo aver rasato a gesso il controsoffitto, l'incasso risulta parte integrante del soffitto stesso e può essere tinteggiato
- Apertura per installazione 83x83 mm.
- Adatto a moduli LED standard MR16

Gypsolyte fitting for counter ceiling (for LED modules)

- Invisible fitting for counter ceilings
- Once the counter ceiling is finished with smoothing plaster, the fitting is almost invisible and can be painted together with the ceiling
- Installation hole mm 83x83
- Suitable for standard MR16 LED modules

Einbaustrahler aus Gypsolyte für Unterdecken (für Led-Modulen geeignet)

- Unsichtbare Einbaustrahler für Unterdecken
- Sobald die Unterdecke durch Gips glatt gemacht ist, wird der Einbaustrahler fast unsichtbar und kann zusammen mit der Unterdecke gemalt werden
- Montageöffnung 83x83 mm.
- Für Standard MR16 LED-Module geeignet

Encastrable en Gypsolyte pour plafond (pour modules à LED)

- Encastrable invisible pour faux plafond
- Après avoir lissé le faux-plafond, le boîtier encastrable devient partie intégrante du faux-plafond lui même et peut être peint
- Ouverture dans le plafond pour l'installation: 83x83 mm.
- Adapté aux modules LED MR16 standard

Cazoleta para falso techo (para módulos de LED) in Gypsolyte

- Cazoleta para falso techo Gypsolyte (para módulos de LED)
- Cazoleta invisible para falsos techos
- Una vez terminado el falso techo con yeso la carcasa es casi invisible y puede ser pintado junto con el techo
- Medidas del orificio para la instalación: 83x83 mm.
- Apropriado para módulos estándar de LED MR16

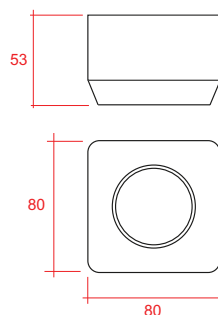



Incassi Gypsolyte • Gypsolyte fixtures

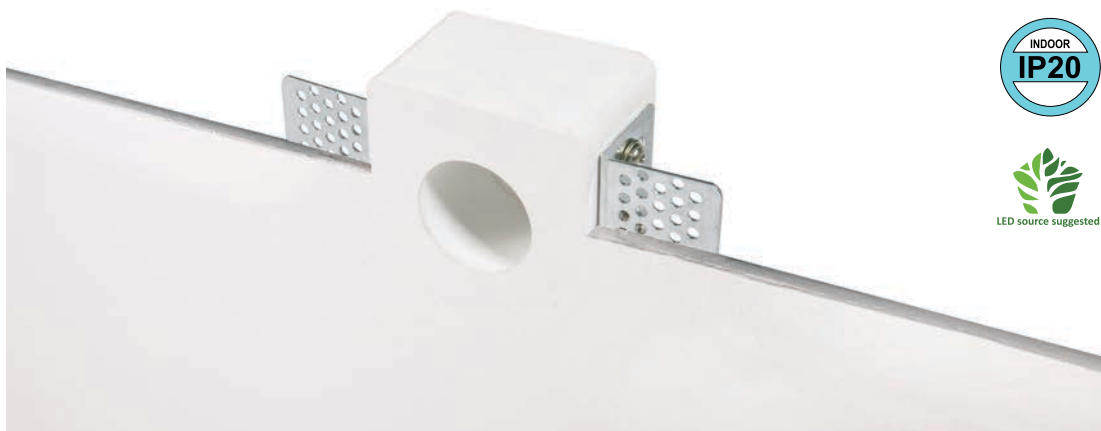

Type	Part n°	Dimensions mm	Standard	Colour	 mm	Packing box dimensions (mm)	Packing box (kg)
SNAP Q1B	B9286G035Q1B	60x60x37h	MR8	White	63x63	100x105x110	0,25

Verdere pagina 168 per i kit che includono la lampadina LED - See page 168 for kits including LED lamp

Incasso in Gypsolyte per controsoffitti (per moduli LED)

- Incasso invisibile per controsoffitti
- Dopo aver rasato a gesso il controsoffitto, l'incasso risulta parte integrante del soffitto stesso e può essere tinteggiato
- Apertura per installazione 63x63 mm.
- Adatto a moduli LED standard MR8 (con adattatore **BAT30X23500B**)

Gypsolyte fitting for counter ceiling (for LED modules)

- Invisible fitting for counter ceilings
- Once the counter ceiling is finished with smoothing plaster, the fitting is almost invisible and can be painted together with the ceiling
- Installation hole mm 63x63
- Suitable for standard MR8 LED modules (with adapter **BAT30X23500B**)

Einbaustrahler aus Gypsolyte für Unterdecken (für Led-Modulen geeignet)

- Unsichtbare Einbaustrahler für Unterdecken
- Sobald die Unterdecke durch Gips glatt gemacht ist, wird der Einbaustrahler fast unsichtbar und kann zusammen mit der Unterdecke gemalt werden
- Montageöffnung 63x63 mm.
- Für Standard MR8 LED-Module geeignet (mit Adaptator **BAT30X23500B**)

Encastrable en Gypsolyte pour plafond (pour modules à LED)

- Encastrable invisible pour faux plafond
- Après avoir lissé le faux-plafond, le boîtier encastrable devient partie intégrante du faux-plafond lui même et peut être peint
- Ouverture dans le plafond pour l'installation: 63x63 mm.
- Adapté aux modules LED MR8 standard (avec adaptateur **BAT30X23500B**)

Cazoleta para falso techo (para módulos de LED) in Gypsolyte

- Cazoleta para falso techo Gypsolyte (para módulos de LED)
- Cazoleta invisible para falsos techos
- Una vez terminado el falso techo con yeso la carcasa es casi invisible y puede ser pintado junto con el techo
- Medidas del orificio para la instalación 63x63 mm.
- Apropriadado para módulos estándar de LED MR8 (con adaptador **BAT30X23500B**)

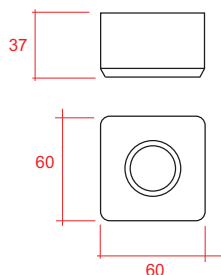

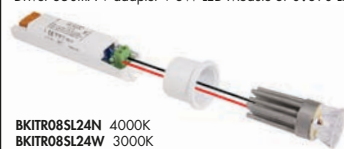

Optional Kit:
Driver 350mA + adapter + 3W LED Module 370+390 Lm



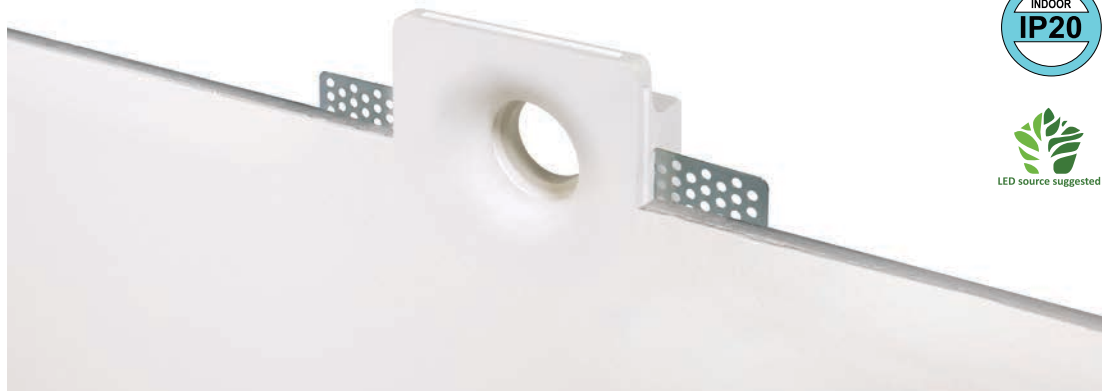

Incassi Gypsolyte • Gypsolyte fixtures



Type	Part n°	Dimensions mm	Standard	Colour	 mm	Packing box dimensions (mm)	Packing box (kg)
LOOP Q1B	B9287G035Q1B	80x80x32h	MR8	White	83x83	157x130x110	0,25

Vedere pagina 168 per i kit che includono la lampadina LED - See page 168 for kits including LED lamp

Incasso in Gypsolyte per controsoffitti (per moduli LED)

- Incasso invisibile per controsoffitti
- Dopo aver rasato a gesso il controsoffitto, l'incasso risulta parte integrante del soffitto stesso e può essere tinteggiato
- Apertura per installazione 83x83 mm.
- Adatto a moduli LED standard MR8 (con adattatore **BAT30X23500B**)

Gypsolyte fitting for counter ceiling (for LED modules)

- Invisible fitting for counter ceilings
- Once the counter ceiling is finished with smoothing plaster, the fitting is almost invisible and can be painted together with the ceiling
- Installation hole mm 83x83
- Suitable for standard MR8 LED modules (with adapter **BAT30X23500B**)

Einbaustrahler aus Gypsolyte für Unterdecken (für Led-Modulen geeignet)

- Unsichtbare Einbaustrahler für Unterdecken
- Sobald die Unterdecke durch Gips glatt gemacht ist, wird der Einbaustrahler fast unsichtbar und kann zusammen mit der Unterdecke gemalt werden
- Montageöffnung 83x83 mm.
- Für Standard MR8 LED-Module geeignet (mit Adaptator **BAT30X23500B**)

Encastrable en Gypsolyte pour plafond (pour modules à LED)

- Encastrable invisible pour faux plafond
- Après avoir lissé le faux-plafond, le boîtier encastrable devient partie intégrante du faux-plafond lui même et peut être peint
- Ouverture dans le plafond pour l'installation: 83x83 mm.
- Adapté aux modules LED MR8 standard (avec adaptateur **BAT30X23500B**)

Cazoleta para falso techo (para módulos de LED) in Gypsolyte

- Cazoleta para falso techo Gypsolyte (para módulos de LED)
- Cazoleta invisible para falsos techos
- Una vez terminado el falso techo con yeso la carcasa es casi invisible y puede ser pintado junto con el techo
- Medidas del orificio para la instalación 83x83 mm.
- Apropriado para módulos estándar de LED MR8 (con adaptador **BAT30X23500B**)

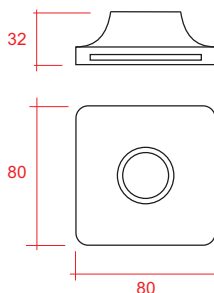

Optional Kit:
Driver 350mA + adapter + 3W LED Module 370+390 Lm

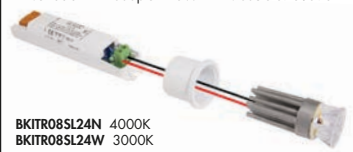

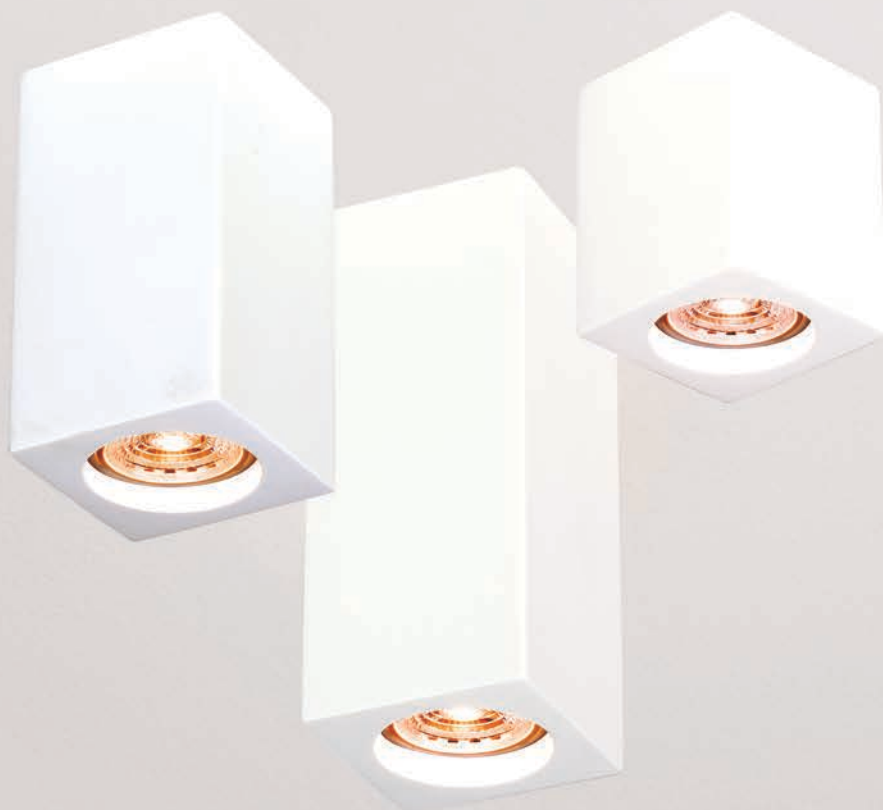

Strutture Gypsolyte • Gypsolyte fixtures



Type	Part n°	Dimensions mm	Standard	Colour	Packing box dimensions (mm)	Packing box (kg)
NEOS SMALL	B9262G050Q1B	71x71x90h	MR16	White	120x120x135h	0,47
NEOS MEDIUM	B9263G050Q1B	71x71x129h	MR16	White	120x120x180h	0,64
NEOS LARGE	B9264G050Q1B	71x71x169h	MR16	White	120x120x210h	0,84

Vedere pagina 168 per i kit che includono la lampadina LED - See page 168 for kits including LED lamp

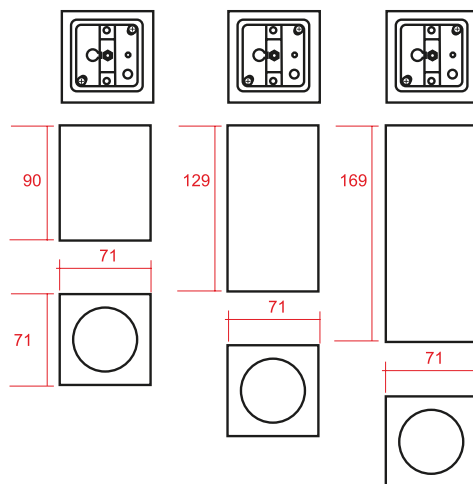

Alloggiamento da soffitto in Gypsolyte

- Struttura in Gypsolyte
- Adatto a moduli LED standard MR16
- Installazione a soffitto

Gypsolyte fixture for ceiling

- Structure in Gypsolyte
- Suitable for standard MR16 LED modules
- To be installed on ceiling

Deckeneinbau aus Gypsolyte

- Körper aus Gypsolyte
- Für Standard MR16 LED
- Module geeignet- Deckeneinsatz

Structure pour plafond en Gypsolyte

- Corps en Gypsolyte
- Adapté aux modules LED MR16 standard
- Installation au plafond

Estructura para techo

- Estructura de Gypsolyte
- Apropriado para modulos estandar LED MR16
- Instalacion para techo





Strutture Gypsolyte • Gypsolyte fixtures



Type	Part n°	Dimensions mm	Standard	Colour	Packing box dimensions (mm)	Packing box (kg)
ARGO SMALL	B9268G050T1B	Ø70x90h	MR16	White	120x120x135h	0,46
ARGO MEDIUM	B9269G050T1B	Ø70x130h	MR16	White	120x120x180h	0,61
ARGO LARGE	B9270G050T1B	Ø70x170h	MR16	White	120x120x210h	0,76

Vedere pagina 168 per i kit che includono la lampadina LED - See page 168 for kits including LED lamp

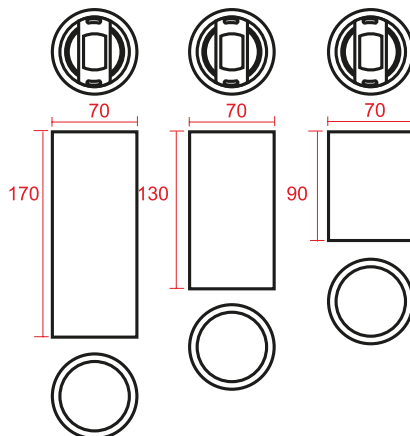

Alloggiamento da soffitto in Gypsolyte

- Struttura in Gypsolyte
- Adatto a moduli LED standard MR16
- Installazione a soffitto

Gypsolyte fixture for ceiling

- Structure in Gypsolyte
- Suitable for standard MR16 LED modules
- To be installed on ceiling

Deckeneinbau aus Gypsolyte

- Körper aus Gypsolyte
- Für Standard MR16 LED
- Module geeignet- Deckeneinsatz

Structure pour plafond en Gypsolyte

- Corps en Gypsolyte
- Adapté aux modules LED MR16 standard
- Installation au plafond

Estructura para techo

- Estructura de Gypsolyte
- Apropriado para modulos estandar LED MR16
- Instalacion para techo

